



Custom Machine & Tool Co., Inc.
 301 Winter St. Unit I
 Hanover, MA 02339
 Email: info@cmtco.com
 WWW.CMTCO.COM
 Tel: 800-355-5949 Or 781-924-1003

2MM GT®2 Synchronous Sprockets

6mm (.236 in) Wide Belts (2MR-06) - .395 Face Width						
Part Number	No. of Grooves	Style	Nominal Dimensions			Length thru Bore
			Pitch Diameter	Outside Diameter	Flange O.D.	
CMT26S-2MR-06-0606	26	3F	0.652	0.632	0.840	0.395
CMT28S-2MR-06-0609	28	3F	0.702	0.682	0.895	0.395
CMT30S-2MR-06-0609	30	3F	0.752	0.732	0.945	0.395
CMT32S-2MR-06-0609	32	3F	0.802	0.782	1.000	0.395
CMT36S-2MR-06-0909	36	3F	0.902	0.882	1.105	0.395
CMT40S-2MR-06-0909	40	3F	1.003	0.983	1.210	0.395
CMT40S-2MR-06-0912	40	6F	1.003	0.983	1.210	0.53
CMT45S-2MR-06-0909	45	3F	1.128	1.108	1.340	0.395
CMT45S-2MR-06-1212	45	6F	1.128	1.108	1.340	0.53
CMT50S-2MR-06-0909	50	3F	1.253	1.233	1.470	0.395
CMT50S-2MR-06-1212	50	6F	1.253	1.233	1.470	0.53
CMT50S-2MR-06-1616	50	6	1.253	1.233	-	0.655
CMT56S-2MR-06-0909	56	3	1.404	1.384	-	0.395
CMT56S-2MR-06-1616	56	6	1.404	1.384	-	0.655
CMT62S-2MR-06-0909	62	3	1.554	1.534	-	0.395
CMT62S-2MR-06-1616	62	6	1.554	1.534	-	0.655
CMT68S-2MR-06-0909	68	3	1.704	1.684	-	0.395
CMT68S-2MR-06-1616	68	6	1.704	1.684	-	0.655
CMT74S-2MR-06-0909	74	3	1.855	1.835	-	0.395
CMT74S-2MR-06-1616	74	6	1.855	1.835	-	0.655
CMT80S-2MR-06-0909	80	3	2.005	1.985	-	0.395
CMT80S-2MR-06-1616	80	6	2.005	1.985	-	0.655

Patent Number 6,568,063 Custom Machine & Tool Co., Inc

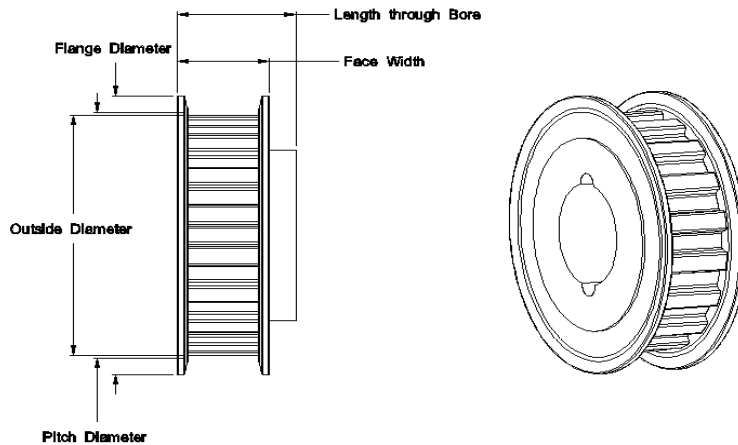

STYLE CODES:

- 3F Flanges both sides no hub
- 3 No flanges no hub
- 6F Flanges both sides with hub (as shown)
- 6 No flanges with hub

CMT® is a registered trademark of Custom Machine & Tool Co., Inc.
 Copyright © 1998-2012 Custom Machine & Tool Co., Inc. All rights reserved.
 GT® is a registered trademark of Gates Corporation