



Custom Machine & Tool Co., Inc.
 22 Station Street
 E, Weymouth, MA 02189
 Email: info@cmtco.com
 WWW.CMTCO.COM
 Tel: 800-355-5949 Or 781-331-7770

3MM Pitch HTD ® Synchronous Sprockets

9mm (.354 in) Wide Belts (3M-09) - .500 Face Width						
Part Number	No. of Grooves	Style	Nominal Dimensions			
			Pitch Diameter	Outside Diameter	Flange O.D.	Length thru Bore
CMT18-3M-09-0606	18	3F	.677	.647	.790	.500
CMT19-3M-09-0609	19	3F	.714	.684	.827	.500
CMT20-3M-09-0609	20	3F	.752	.722	.895	.500
CMT22-3M-09-0609	22	3F	.827	.797	.945	.500
CMT24-3M-09-0909	24	3F	.902	.872	1.025	.500
CMT26-3M-09-0909	26	3F	.977	.947	1.105	.500
CMT28-3M-09-0909	28	3F	1.053	1.023	1.173	.500
CMT30-3M-09-1212	30	6F	1.128	1.098	1.250	.550
CMT32-3M-09-1212	32	6F	1.203	1.173	1.323	.550
CMT34-3M-09-1212	34	6F	1.278	1.248	1.398	.550
CMT36-3M-09-1212	36	6F	1.353	1.324	1.473	.550
CMT38-3M-09-1212	38	6F	1.429	1.399	1.549	.550
CMT40-3M-09-1212	40	6F	1.504	1.474	1.625	.550
CMT44-3M-09-1212	44	6F	1.654	1.624	1.775	.550
CMT50-3M-09-1616	50	6	1.88	1.850	-	.700
CMT56-3M-09-1616	56	6	2.105	2.075	-	.700
CMT62-3M-09-1616	62	6	2.331	2.301	-	.700
CMT72-3M-09-1616	72	6	2.707	2.677	-	.700

Patent Number 6,568,063 Custom Machine & Tool Co., Inc

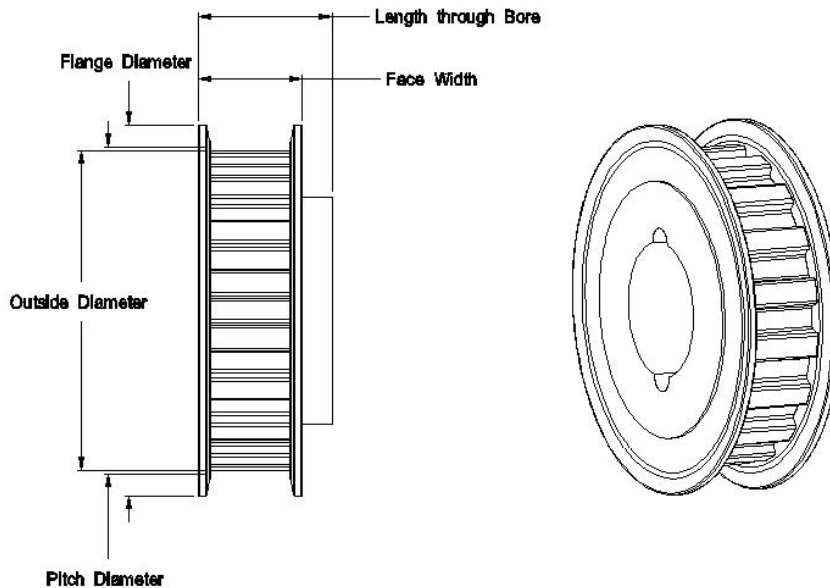

STYLE CODES:

- 3F Flanges both sides no hub
- 3 No flanges no hub
- 6F Flanges both sides with hub (as shown)
- 6 No flanges with hub

CMT® is a registered trademark of Custom Machine & Tool Co., Inc.
 Copyright © 1998-2004 Custom Machine & Tool Co., Inc. All rights reserved.
 HTD ® is a registered trademark of Gates Corporation