



Custom Machine & Tool Co., Inc.  
 301 Winter St. Unit I  
 Hanover, MA 02339  
 Email: info@cmtco.com  
 WWW.CMTCO.COM  
 Tel: 800-355-5949 Or 781-924-1003

### 5M HTD ® Synchronous Sprockets

9mm (.354 in) Wide Belts (5M-09) - .550 Face Width						
Part Number	No. of Grooves	Style	Nominal Dimensions			
			Pitch Diameter	Outside Diameter	Flange O.D.	Length thru Bore
CMT14-5M-09-0609	14	3F	.877	.832	1.000	.550
CMT15-5M-09-0909	15	3F	.940	.895	1.063	.550
CMT16-5M-09-0909	16	3F	1.003	.958	1.094	.550
CMT17-5M-09-0909	17	3F	1.065	1.020	1.187	.550
CMT18-5M-09-0909	18	3F	1.128	1.083	1.250	.550
CMT19-5M-091212	19	3F	1.191	1.146	1.312	.550
CMT20-5M-09-1212	20	3F	1.253	1.208	1.375	.550
CMT22-5M-09-1212	22	3F	1.379	1.334	1.500	.550
CMT24-5M-09-1212	24	3F	1.504	1.459	1.625	.550
CMT26-5M-09-1212	26	3F	1.629	1.584	1.750	.550
CMT28-5M-09-1616	28	3F	1.754	1.709	1.875	.660
CMT30-5M-09-1616	30	6F	1.880	1.835	2.000	.660
CMT32-5M-09-1616	32	6F	2.005	1.960	2.125	.660
CMT34-5M-09-1616	34	6F	2.130	2.085	2.250	.660
CMT36-5M-09-1616	36	6	2.256	2.211	-	.660
CMT38-5M-09-2020	38	6	2.381	2.336	-	.820
CMT40-5M-09-2020	40	6	2.506	2.461	-	.820
CMT44-5M-09-2020	44	6	2.757	2.712	-	.820
CMT50-5M-09-2020	50	6	3.133	3.088	-	.820
CMT56-5M-09-2020	56	6	3.509	3.464	-	.820
CMT62-5M-09-2020	62	6	3.885	3.840	-	.820
CMT72-5M-09-2020	72	6	4.511	4.466	-	.820

Patent Number 6,568,063 Custom Machine & Tool Co., Inc

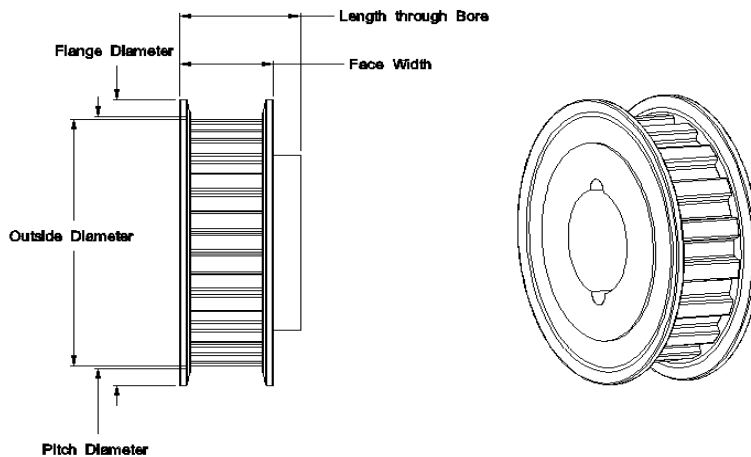

#### STYLE CODES:

- 3F Flanges both sides no hub
- 3 No flanges no hub
- 6F Flanges both sides with hub (as shown)
- 6 No flanges with hub

CMT® is a registered trademark of Custom Machine & Tool Co., Inc.  
 Copyright © 1998-2012 Custom Machine & Tool Co., Inc. All rights reserved.  
 HTD ® is a registered trademark of Gates Corporation