



Custom Machine & Tool Co., Inc.
 22 Station Street
 E, Weymouth, MA 02189
 Email: info@cmtco.com
 WWW.CMTCO.COM
 Tel: 800-355-5949 Or 781-331-7770

5M HTD ® Synchronous Sprockets

Part Number	No. of Grooves	Style	Nominal Dimensions			
			Pitch Diameter	Outside Diameter	Flange O.D.	Length thru Bore
CMT14-5M-15-0609	14	3F	.877	.832	1.000	.781
CMT15-5M-15-0912	15	3F	.940	.895	1.063	.781
CMT16-5M-15-0912	16	3F	1.003	.958	1.094	.781
CMT17-5M-15-0912	17	3F	1.065	1.020	1.187	.781
CMT18-5M-15-1212	18	3F	1.128	1.083	1.250	.781
CMT19-5M-15-1212	19	3F	1.191	1.146	1.312	.781
CMT20-5M-15-1216	20	3F	1.253	1.208	1.375	.781
CMT22-5M-15-1216	22	3F	1.379	1.334	1.500	.781
CMT24-5M-15-1620	24	6F	1.504	1.459	1.625	.820
CMT26-5M-15-1620	26	6F	1.629	1.584	1.750	.820
CMT28-5M-15-2025	28	6F	1.754	1.709	1.875	1.050
CMT30-5M-15-2025	30	6F	1.880	1.835	2.000	1.050
CMT32-5M-15-2025	32	6F	2.005	1.960	2.125	1.050
CMT34-5M-15-2025	34	6F	2.130	2.085	2.250	1.050
CMT36-5M-15-2025	36	6	2.256	2.211	-	1.050
CMT38-5M-15-2025	38	6	2.381	2.336	-	1.050
CMT40-5M-15-2025	40	6	2.506	2.461	-	1.050
CMT44-5M-15-2025	44	6	2.757	2.712	-	1.050
CMT50-5M-15-2025	50	6	3.133	3.088	-	1.050
CMT56-5M-15-2025	56	6	3.509	3.464	-	1.050
CMT62-5M-15-2025	62	6	3.885	3.840	-	1.050
CMT72-5M-15-2025	72	6	4.511	4.466	-	1.050

Patent Number 6,568,063 Custom Machine & Tool Co., Inc

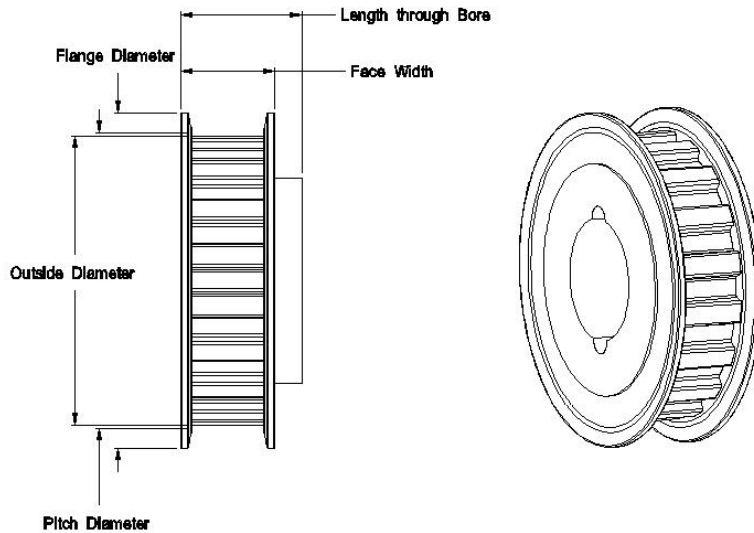

STYLE CODES:

- 3F Flanges both sides no hub
- 3 No flanges no hub
- 6F Flanges both sides with hub (as shown)
- 6 No flanges with hub

CMT® is a registered trademark of Custom Machine & Tool Co., Inc.
 Copyright © 1998-2004 Custom Machine & Tool Co., Inc. All rights reserved.
 HTD ® is a registered trademark of Gates Corporation