



**Custom Machine & Tool Co., Inc.**  
**22 Station Street**  
**E, Weymouth, MA 02189**  
**Email: info@cmtco.com**  
**WWW.CMTCO.COM**  
**Tel: 800-355-5949 Or 781-331-7770**

### MXL .080 Timing Belt Synchronous Sprockets

.375 Wide Belts - .530 Face Width						
Part Number	No. of Grooves	Style	Nominal Dimensions			
			Pitch Diameter	Outside Diameter	Flange O.D.	Length thru Bore
CMT24-MXL-037-0606	24	3F	.611	.591	.815	.530
CMT25-MXL-037-0606	25	3F	.637	.617	.815	.530
CMT28-MXL-037-0609	28	3F	.713	.693	.895	.530
CMT30-MXL-037-0609	30	3F	.764	.744	.945	.530
CMT32-MXL-037-0909	32	3F	.815	.795	1.000	.530
CMT25-MXL-037-0909	36	3F	.917	.897	1.105	.530
CMT40-MXL-037-0909	40	3F	1.019	.999	1.210	.530
CMT42-MXL-037-1212	42	3F	1.070	1.050	1.260	.530
CMT44-MXL-037-1212	44	3F	1.120	1.100	1.315	.530
CMT48-MXL-037-1212	48	3F	1.222	1.202	1.420	.530
CMT60-MXL-037-1212	60	3F	1.528	1.508	1.730	.530
CMT60-MXL-037-1616	60	6	1.528	1.508	-	.650
CMT72-MXL-037-1616	72	6	1.833	1.813	-	.650
CMT80-MXL-037-1616	80	6	2.037	2.017	-	.650
CMT90-MXL-037-1616	90	6	2.292	2.272	-	.650
CMT100-MXL-037-1616	100	6	2.546	2.526	-	.650
CMT120-MXL-037-1616	120	6	3.056	3.036	-	.650

Patent Number 6,568,063 Custom Machine & Tool Co., Inc

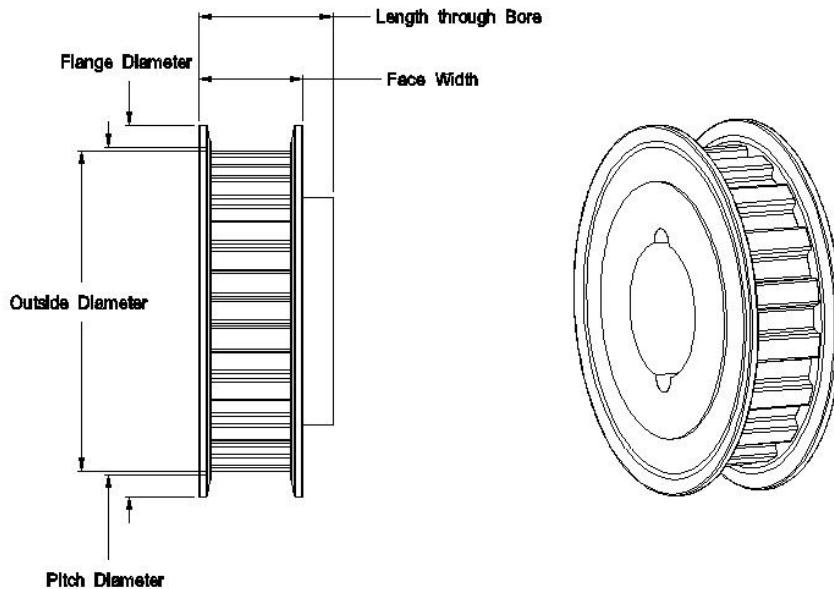

**STYLE CODES:**

- 3F** Flanges both sides no hub
- 3** No flanges no hub
- 6F** Flanges both sides with hub (as shown)
- 6** No flanges with hub

**CMT® is a registered trademark of Custom Machine & Tool Co., Inc.**  
**Copyright © 1998-2004 Custom Machine & Tool Co., Inc. All rights reserved.**