



**Custom Machine & Tool Co., Inc.**  
**22 Station Street**  
**E, Weymouth, MA 02189**  
**Email: info@cmtco.com**  
**WWW.CMTCO.COM**  
**Tel: 800-355-5949 Or 781-331-7770**

## XL .200 Timing Belt Synchronous Sprockets

Part Number	No. of Grooves	Style	Nominal Dimensions			
			Pitch Diameter	Outside Diameter	Flange O.D.	Length thru Bore
			<b>.375 Wide Belts - .563 Face Width</b>			
CMT11-XL-037-0606	11	3F	.700	.680	.938	.563
CMT12-XL-037-0609	12	3F	.764	.744	1.000	.563
CMT14-XL-037-0909	14	3F	.891	.871	1.094	.563
CMT15-XL-037-0912	15	3F	.955	.935	1.188	.563
CMT16-XL-037-0912	16	3F	1.019	.999	1.250	.563
CMT17-XL-0371212	17	3F	1.082	1.062	1.313	.563
CMT18-XL-037-1212	18	3F	1.146	1.126	1.375	.563
CMT20-XL-037-1212	20	3F	1.273	1.253	1.500	.563
CMT21-XL-037-1212	21	3F	1.337	1.317	1.563	.563
CMT22-XL-037-1212	22	3F	1.401	1.381	1.625	.563
CMT24-XL-037-1616	24	6F	1.528	1.508	1.750	.700
CMT25-XL-037-1616	25	6F	1.592	1.572	1.813	.700
CMT28-XL-037-1616	28	6F	1.783	1.763	2.000	.700
CMT30-XL-037-1616	30	6F	1.910	1.890	2.125	.700
CMT32-XL-037-1616	32	6F	2.037	2.017	2.250	.700
CMT36-XL-037-2020	36	6	2.292	2.272	-	.810
CMT40-XL-037-2020	40	6	2.546	2.526	-	.810
CMT42-XL-037-2020	42	6	2.674	2.654	-	.810
CMT44-XL-037-2020	44	6	2.801	2.781	-	.810
CMT48-XL-037-2020	48	6	3.056	3.036	-	.810
CMT60-XL-037-2020	60	6	3.820	3.800	-	.810
CMT72-XL-037-2020	72	6	4.584	4.564	-	.810

Patent Number 6,568,063 Custom Machine & Tool Co., Inc

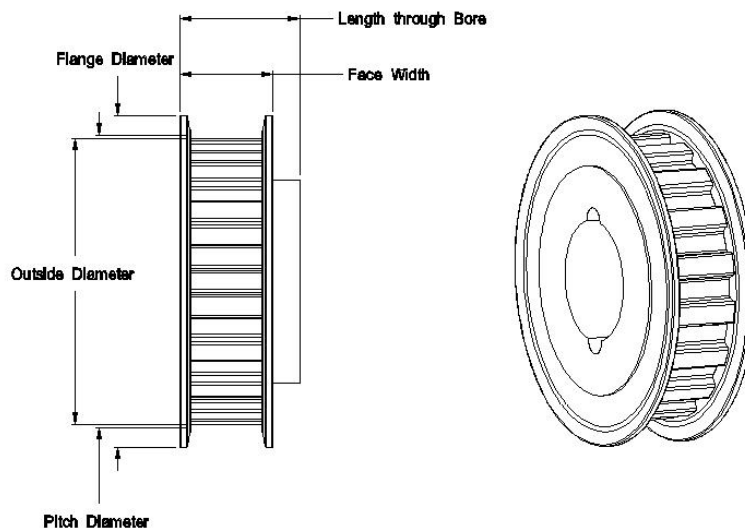

### STYLE CODES:

- 3F** Flanges both sides no hub
- 3** No flanges no hub
- 6F** Flanges both sides with hub (as shown)
- 6** No flanges with hub

**CMT® is a registered trademark of Custom Machine & Tool Co., Inc.**  
**Copyright © 1998-2004 Custom Machine & Tool Co., Inc. All rights**