



Custom Machine & Tool Co., Inc.  
 301 Winter St. Unit I  
 Hanover, MA 02339  
 Email: info@cmtco.com  
 WWW.CMTCO.COM  
 Tel: 800-355-5949 Or 781-924-1003

## XL .200 Timing Belt Synchronous Sprockets Molded Nylon

.375 Wide Belts - .45 Face Width						
Part Number	No. of Grooves	Style	Nominal Dimensions			
			Pitch Diameter	Outside Diameter	Flange O.D.	Length thru Bore
CMT20-XL-037P-1212	20	SF,DF	1.273	1.253	1.50	.61
CMT21-XL-037P-1212	21	SF,DF	1.337	1.317	1.57	.61
CMT22-XL-037P-1212	22	SF,DF	1.401	1.381	1.63	.61
CMT24-XL-037P-1212	24	SF,DF	1.528	1.508	1.76	.61
CMT25-XL-037P-1212	25	SF,DF	1.592	1.572	1.80	.61
CMT26-XL-037P-1212	26	SF,DF	1.655	1.635	1.87	.61
CMT27-XL-037P-1212	27	SF,DF	1.719	1.699	1.94	.61
CMT28-XL-037P-1212	28	SF,DF	1.783	1.763	2.02	.61
CMT29-XL-037P-1212	29	SF,DF	1.846	1.826	2.07	.61
CMT30-XL-037P-1212	30	SF,DF	1.910	1.890	2.14	.61
CMT32-XL-037P-1212	32	SF,DF,NF	2.037	2.017	2.26	.61
CMT36-XL-037P-1212	36	SF,DF,NF	2.292	2.272	2.51	.61
CMT40-XL-037P-1212	40	SF,DF,NF	2.546	2.526	2.78	.61
CMT42-XL-037P-1212	42	SF,DF,NF	2.674	2.654	2.90	.61
CMT48-XL-037P-1212	48	SF,DF,NF	3.056	3.036	3.28	.61
CMT60-XL-037P-1212	60	SF,DF,NF	3.820	3.800	4.01	.61
CMT72-XL-037P-1212	72	SF	4.584	4.564	4.82	.61

Patent Number 6,568,063 Custom Machine & Tool Co., Inc

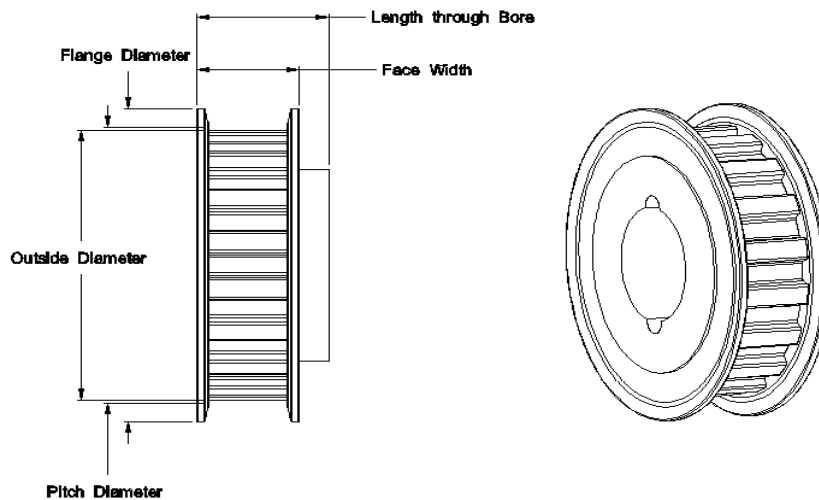

### STYLE CODES:

- SF Flange with hub
- DF Flange with hub
- NF No flanges with hub

CMT® is a registered trademark of Custom Machine & Tool Co., Inc.  
 Copyright © 1998-2012 Custom Machine & Tool Co., Inc. All rights reserved.